

THIS DRAWING IS UNPUBLISHED. RELEASED FOR PUBLICATION
 © COPYRIGHT BY TYCO ELECTRONICS CORPORATION. ALL RIGHTS RESERVED.

LOC	DIST	REVISIONS			
P	LTR	DESCRIPTION	DATE	DWN	APVD
CM	54	D	ECO-07-012888	22JUN07	KW DB

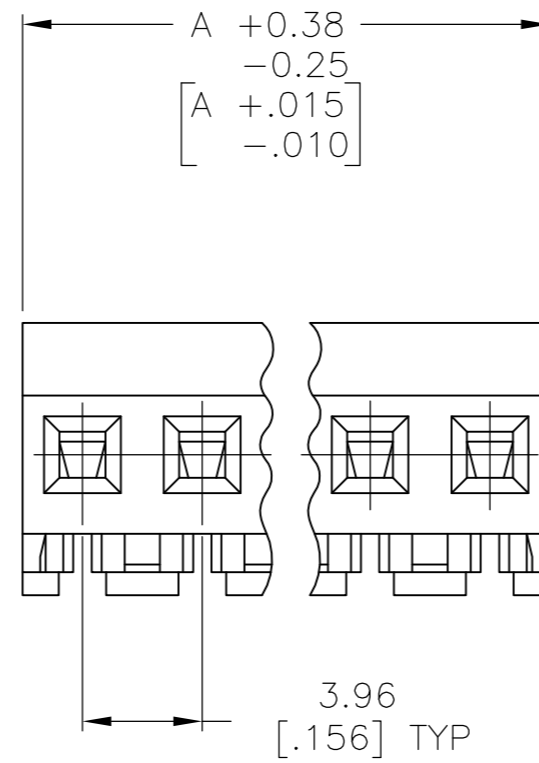
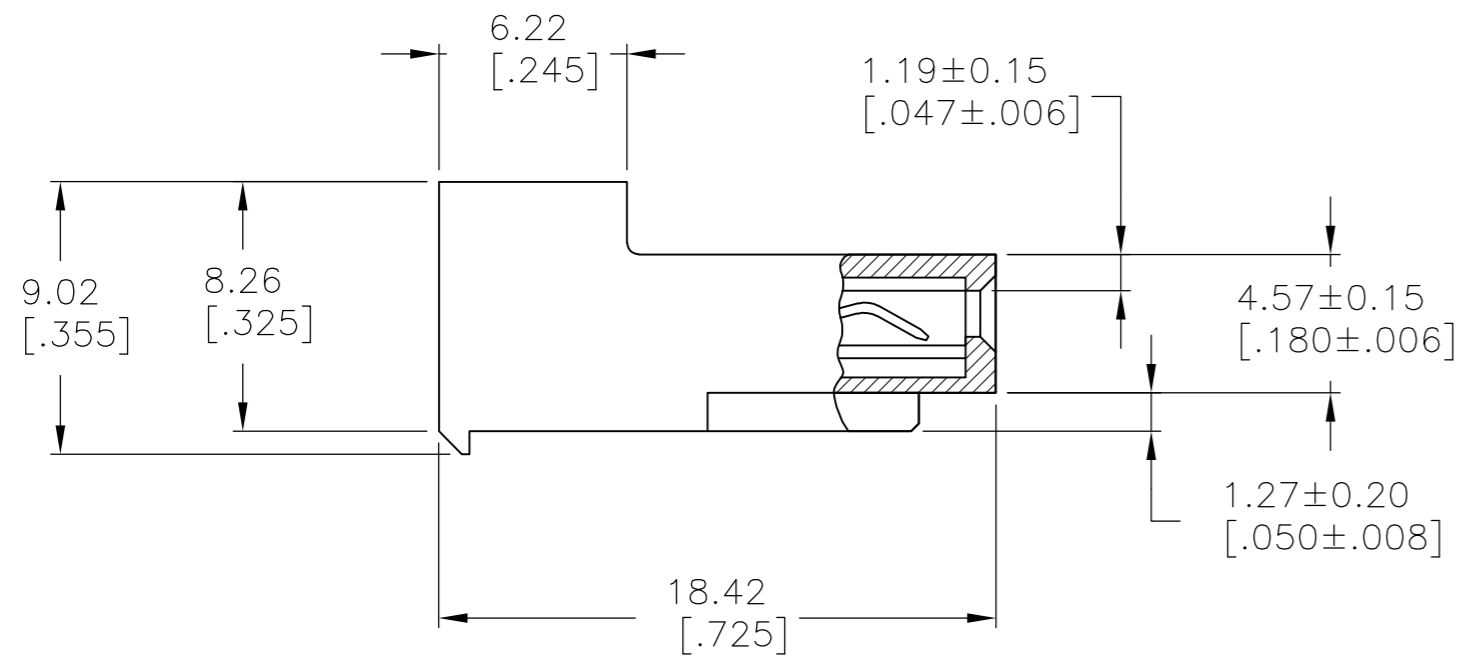
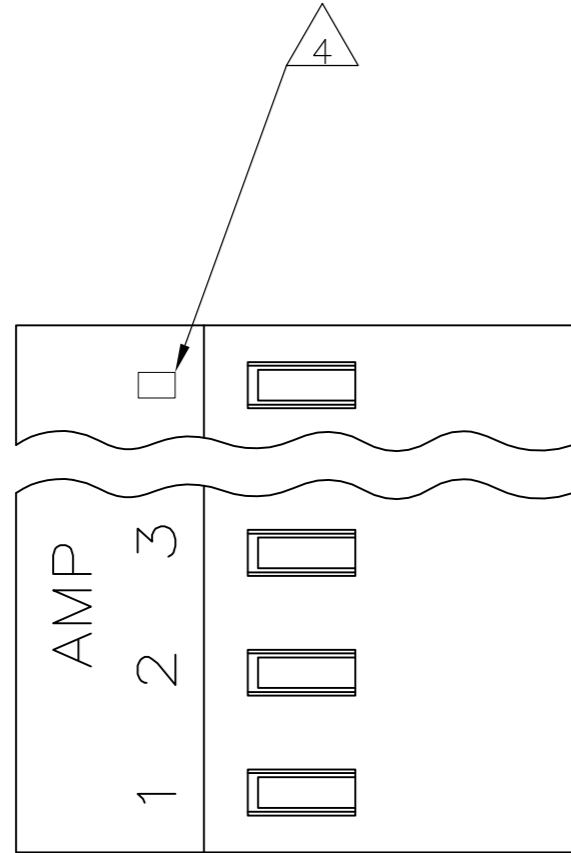

- 1 MATERIAL: CONNECTOR - NYLON UL94V-0 (BLACK).
 CONTACTS - 0.30[.012] THICK COPPER ALLOY
 (BRIGHT-TIN LEAD 0.00203
 [.000080] MIN THK FOR CONTACTS
 644502-2 THRU 1-644502-2, MATTE
 WHISKER MITIGATED TIN 0.00203 [.000080]
 MIN THICKNESS FOR CONTACTS
 3-644502-2 THRU 4-644502-2)
- 2. CONTACTS ACCEPT 18 AWG WIRE WITH 2.41[.095] MAX INSULATION DIAMETER.
- 3. CONTACTS MUST ACCEPT 1.14±0.03[.045±.001] SQUARE POST AND REMAIN LOCKED IN POSITION.
- 4 IDENTIFICATION NUMBER FOR LAST CIRCUIT MAY NOT APPEAR ON ALL ASSEMBLIES.
- 5. DIMENSIONS IN BRACKETS ARE IN INCHES.
- 6. HOUSING FEATURES ARE: CLOSED END WITHOUT LOCKING RAMP.

47.55 [1.872]	12	4-644502-2
43.59 [1.716]	11	4-644502-1
39.62 [1.560]	10	4-644502-0
35.66 [1.404]	9	3-644502-9
31.70 [1.248]	8	3-644502-8
27.74 [1.092]	7	3-644502-7
23.77 [.936]	6	3-644502-6
19.81 [.780]	5	3-644502-5
15.85 [.624]	4	3-644502-4
11.89 [.468]	3	3-644502-3
7.92 [.312]	2	3-644502-2
47.55 [1.872]	12	1-644502-2
43.59 [1.716]	11	1-644502-1
39.62 [1.560]	10	1-644502-0
35.66 [1.404]	9	644502-9
31.70 [1.248]	8	644502-8
27.74 [1.092]	7	644502-7
23.77 [.936]	6	644502-6
19.81 [.780]	5	644502-5
15.85 [.624]	4	644502-4
11.89 [.468]	3	644502-3
7.92 [.312]	2	644502-2
DIM A	NO. OF CIRCUITS	PART NO.

THIS DRAWING IS A CONTROLLED DOCUMENT.		DWN B. LEWIS 12FEB91	Tyco Electronics Corporation Harrisburg, Pa 17105-3608	
DIMENSIONS: mm [INCHES]		CHK R. SWING 12FEB91	Tyco Electronics Corporation	
TOLERANCES UNLESS OTHERWISE SPECIFIED:		APVD D. CLARK 20FEB91	NAME MTA 156 CONNECTOR ASSEMBLY, 18 AWG,UL94V-0, SPECIAL	
0 PLC ± - 1 PLC ± - 2 PLC ± - 3 PLC ± - 4 PLC ± - ANGLES ± -		PRODUCT SPEC 108-1051	SIZE A2	CAGE CODE 00779
MATERIAL		APPLICATION SPEC 114-1020	DRAWING NO C=644502	RESTRICTED TO
FINISH		WEIGHT	SCALE 4:1	SHEET 1 OF 1
CUSTOMER DRAWING		REV D		

